



# **SMART Wheelchair**



## **User Manual**

### **Version 5**

© CALL Centre, 2000

**Don't panic !**

**Phone 01635 37550**

**Play and Exploration are the cornerstones of learning.** A person with poor co-ordination and control, communication problems, or one who cannot walk, has less chance to explore and play and is less effective when they do so.

For a person with all these problems, learning is difficult. It's a vicious circle - lack of physical control means no mobility - no mobility restricts the ability to explore the surroundings thus leading to an inability to learn *how* to learn. Communicating with others involves new learning - tasks like tracking, scanning or coding. Even if learning is successful, the results don't transfer because the skills needed for another task, say mobility, are rarely the same.

The Smart Wheelchair was designed to help, by providing:

- a common learning environment for communication, mobility, and some structured play and exploration, in which skills transfer from task to task.
- some relief from the responsibility for mundane mobility tasks, whilst new skills are acquired.

This Manual should be read in conjunction with the Wheelchair Playbook, which sketches out things to do with the Smart Wheelchair, as well as outlining some of the background to its development.

### **How to Use this Manual**

The Smart Wheelchair design has been evolving since 1991, and this process continues. As we discover new uses for the wheelchair and add new features, we will be issuing new versions of the Manual. This can be quite confusing, especially if you try to use an old version of the Manual or if you have to look through the new version to find out what is changed.

As we introduce new information, these will be given out as amendment sheets that can be inserted into the appropriate place and the old sheet removed if required.

Any comments or suggestions that you would like to see incorporated into the Manual will be gratefully received by Smile Rehab and CALL.

# **Have fun!**

# CONTENTS

<b>1</b>	<b>The Smart Wheelchair: An Introduction</b>	
	What is the Smart Wheelchair?	1.1
	What the wheelchair does	1.2
	Who's running this thing anyway?	1.3
<b>2</b>	<b>The Smart Wheelchair: A Description</b>	
	The Smart Wheelchair	2.1
	The Smart Controller, Power Module and Controls	2.2
	The Drive Wheels	2.3
	Seating	2.3
	Battery Charging	2.4
<b>3</b>	<b>Smart Wheelchair Controller</b>	
	Smart Wheelchair Controller box	3.1
	Switching on and off	3.1
	The chair switches itself off	3.1
	'OK so what do I do now?'	3.2
<b>4</b>	<b>Driving the chair with switches</b>	
	Types of switches	4.1
	Connecting switches	4.1
	Choosing switches	4.2
	Switch connectors	4.2
<b>5</b>	<b>Smart Wheelchair ToolBox</b>	
	Adjusting Speed	5.1
	Adjusting Distance	5.1
	Adjusting Response	5.2
	Using the Programme switch on the ToolBox	5.2
	Programming speeds	5.3
	Programming veer	5.3
	Programming distance for 'Timed' motion	5.4
	Programming chair response	5.4
	Programming switch response	5.4
	Resetting default values	5.5
	Muting Tool speech feedback	5.5
	Software version	5.5
<b>6</b>	<b>Smart Wheelchair Motion Tools</b>	
	Motion Tools	6.1

	Characteristics and functions of Motion Tools	6.1
	Selecting separate go and turn Motion Tools	6.2
<b>7</b>	<b>Integrating a computer or communication device to the chair</b>	
	Using the Switch Output sockets	7.1
	Driving the chair with a computer or communication aid	7.2
	Sending commands to the chair	7.2
<b>8</b>	<b>Driving with the Scanner</b>	
	The Scanner box	8.1
	Function of the Scanner and Scan Leds	8.2
	Scan Leds	8.2
	Visual Feedback using the Scanner and Scan Leds	8.3
	Scanner Tools	8.4
	One switch scan	8.4
	Two switch scan	8.4
	4/8 direction scan	8.5
	Smart scan	8.5
	Auditory Scanning	8.5
	Setting scan speed	8.5
	Setting number of scan cycles	8.5
	Three switch scan	8.5
	Three switch smart scan	8.6
<b>9</b>	<b>Smart Wheelchair Bump Tools</b>	
	Bump Tools	9.1
	No bump	9.2
	Bump and Stop	9.2
	Bump and Backoff	9.2
	Bump and Turn	9.2
	Bump and Choose Turn	9.2
	Bump and Avoid	9.3
	User/chair Bump Control	9.3
	Programming the Bump parameters	9.3
	Bumper fault finding and adjusting sensitivity	9.4
<b>10</b>	<b>Smart Wheelchair Line Follower Tools</b>	
	Line Follower Tools	10.1
	Line Following On	10.1
	Line Following with Junctions	10.1
	junction Scanning	10.1
	Safety Fence	10.2
	User/chair Line Control	10.2
	Line Follower accuracy	10.2

Line Follower box and tape	10.3
Who might use a Line Follower?	10.3
Finding the line	10.5
Following the line	10.5
Leaving the line	10.6
Line Junctions	10.6
Laying out a line	10.6
Line Follower tape	10.6
Corners	10.6
Line Follower ‘circuits’	10.7
Line Junctions	10.7
Who might use a Doorway Funne?	10.9
Using a Doorway Funnel	10.10
Laying tape for a Doorway Funnel	10.11
<b>11 Smart Wheelchair Observer Speech Tool</b>	<b>11.1</b>
<b>12 Maintenance and safety</b>	
Maintenance	12.1
General	12.1
Electronic components	12.1
Safety warnings	12.2
Supervision	12.2
The wheelchair must not be operated...	12.2
In case of fire	12.2
General use	12.3
Emergency stop	12.3
Weight and lifting	12.3
Transporting the chair	12.3
Electronics and controls	12.4
Trouble-shooting	12.5
The chair will not switch on	12.5
The green light on the Smart Controller flashes when you switch on	12.5
The chair stops and the red light on the Smart Controller comes on	12.5
The chair drives in different directions when I press the forward switch	12.5
The chair chats away as though it’s stuck in a loop and behaves strangely when I switch on	12.5
The green light on the joystick flashes when you switch on	12.6
The chair does not move when I press the switch	12.7
The chair does not follow the line properly	12.8
Suppliers	12.9
	.

# 1 The Smart Wheelchair: An Introduction

---

## What is the Smart Wheelchair?

The Smart Wheelchair is an electric wheelchair with a computer-based controller and special sensors which help the wheelchair pilot in three different ways:

- Firstly, the Smart systems provide some safeguards for riders who cannot control the wheelchair completely independently. The special bumpers and sensors do not make the wheelchair completely safe though - responsibility for safety still lies with the pilot and his or her helpers and carers.
- Secondly, the Smarts can help the rider control the wheelchair by taking over some of the responsibility for steering and avoiding objects until he or she is ready to handle the job. The amount of work that the rider chooses to do, and how much control is taken by the chair is decided by the rider and his or her carers.

This division of labour can range from:

1. (at one extreme) total driver control of the wheelchair through the controls in the normal way, to
  2. (at the other extreme) allowing the wheelchair to decide where it is going, with the rider merely demanding when to move, and steering and stopping being controlled by the wheelchair.
- The wheelchair can also integrate with communication aids and computers; the pilot can use the same controls to drive the wheelchair and operate another assistive device, or even use the communication aid or computer to drive the wheelchair directly. This same system also allows you to put the control of the wheelchair into the care of smarter computers than the internal one it carries round with it, although we won't be describing this aspect in any detail here.

# What the Wheelchair does

Mobility is fun, exciting and motivating. Being able to move opens up new opportunities for play and exploration. Mobile children and adults are more curious, active, assertive, and learn more effectively. People with very severe physical, communication, sensory or learning difficulties have even more to gain from powered mobility because they have very few other ways to demonstrate their individuality, and experience control. Yet controlling a powered wheelchair is hard for many people with severe disabilities. The Smart Wheelchair was therefore designed with several beliefs in mind:

- (1) When you are learning a new and difficult task, it helps to be able to share some of the load with someone or something else. In this case, your partner is the wheelchair.
- (2) Some skills which you might use for communication purposes (such as switching and tracking) shouldn't have to be relearned for mobility purposes, and vice versa.
- (3) It should be possible to progress gently from simpler to more complex tasks as your skill level increases.

You can think of the wheelchair as an assistant which can take some of the load from you whilst you are learning to drive or communicate and which makes it simpler to transfer skills from one task to another. *You and the wheelchair share the work.* How much each of you does is up to you: you can change your mind and take more control yourself, or decide to hand over more responsibility to the wheelchair at any time.

The diagram below shows how the pilot uses the chair's facilities to gradually develop better driving skills whilst reducing the amount of control taken by the chair itself.

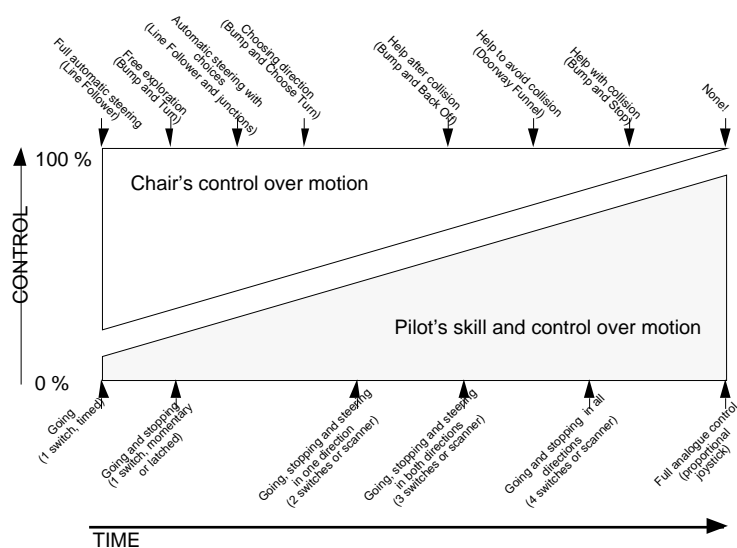

## Who's running this thing anyway

What sort of work might you share? When you're driving a powered wheelchair there are several decisions to be made and tasks to be performed. You have to decide *where* you want to go, and *what* sequence of movements must be made in order to get there. To actually make these movements, you must be able to *start*, *stop* and *steer* the wheelchair. You might also have to try to avoid unexpected obstacles or get out of trouble if you do collide with them. The wheelchair is able to help with some of the more simple tasks to do with moving or dealing with collisions. The central idea is that you can concentrate on learning and practising one task while the wheelchair takes care of another. For example, you might want the wheelchair to deal with bumps, or guide you from room to room, while you get on with the important things like deciding when to move.



## 2 The Smart Wheelchair: A Description

### The Smart Wheelchair

Let's have a guided tour of the wheelchair chassis with the footplates removed:

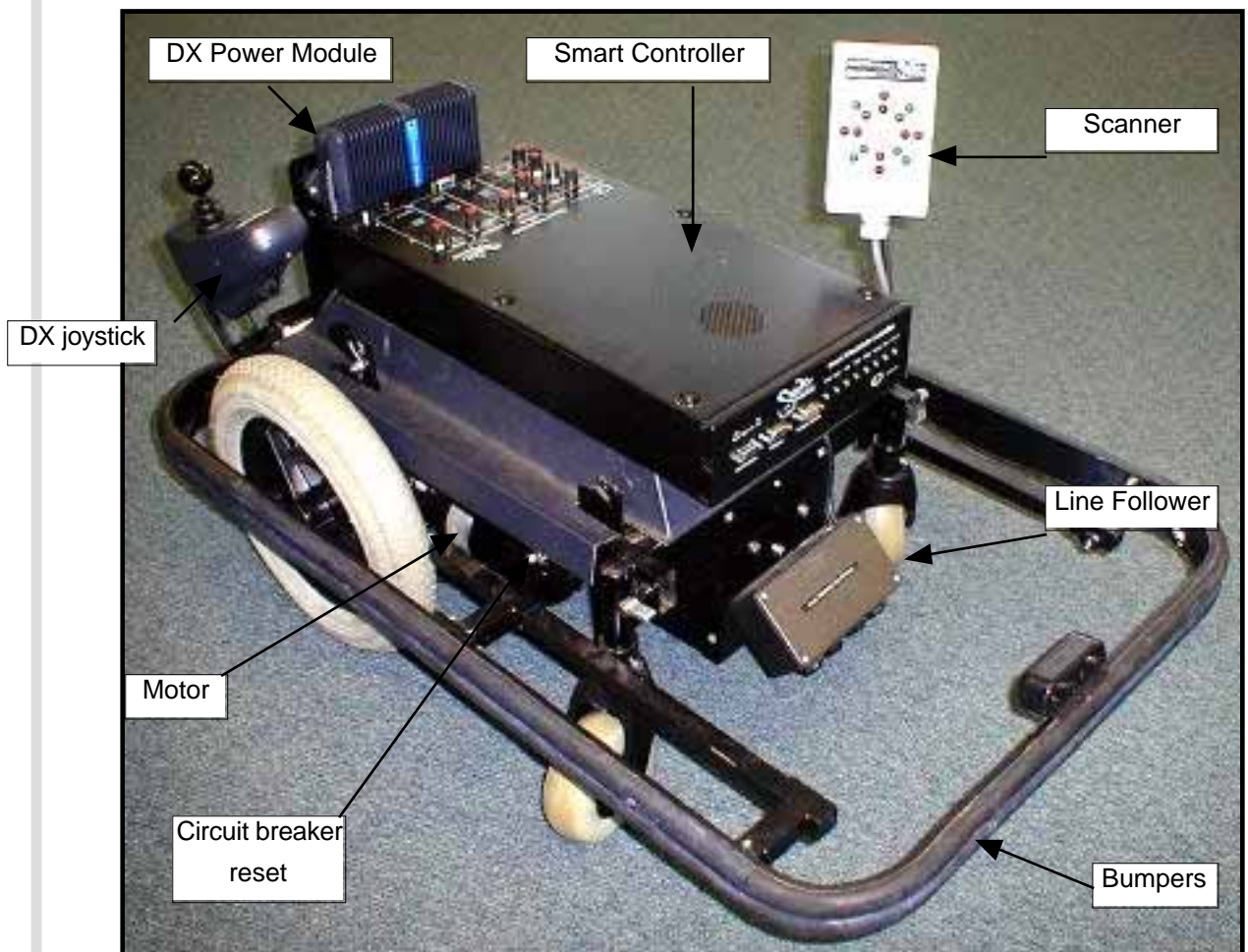

The Smart Wheelchair consists of the:

- wheelchair chassis
- 'DX Power Module', which drives the wheels
- 'DX joystick', which can be used by a helper to drive the chair
- Smart Wheelchair Controller, which contains the computer that controls the system
- Bumpers
- Line Follower
- Scanner

## The Smart Controller, Power Module and Controls

Underneath the seat and on top of the battery box is the Smart Wheelchair Controller, and the Control Dynamics DX Power Module. There will also be a Control Dynamics joystick, which is usually mounted on the back of the user's seat. The joystick and the Smart Controller are both DX 'modules', that send signals along the 'DX bus' to the Power Module. The Power Module converts the signals into high current outputs for driving the two motors. The DX Power Module is fully programmable to cater for a wide range of chair types and user needs. Correct installation and programming are essential to ensure optimum performance and safety. The Power Module has been pre-programmed for the Smart Wheelchair chassis and electronics: these settings must not be changed. Any adjustments to speeds and other options must be made using the Smart Wheelchair programming options, described in Section 5.

The joystick allows the chair to be driven by a helper or attendant. The joystick and Smart Wheelchair Controller **MUST** be connected to the Power Module for correct operation of the Smart Wheelchair.

The main wheelchair off/on switch is the large white oblong pad towards the top of the joystick. You press it once to turn the chair on and then press it again to turn the chair off.

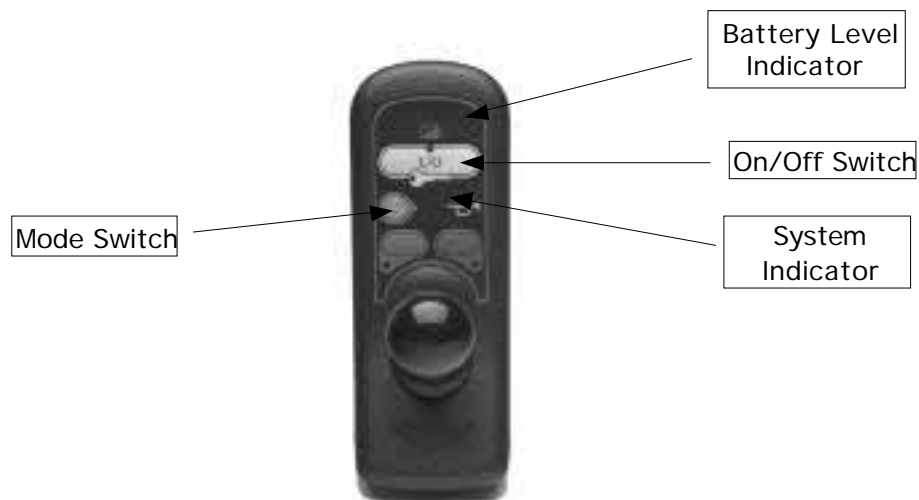

The blue Mode button switches control of the chair between the joystick and the Smart Controller. To drive the chair with the joystick press the mode button till the Mode indicator reads 2; to switch back to driving with the Smart Controller press the Mode button again so that the indicator reads 1.

**NOTE:** The Smart Wheelchair sensors and systems (Bumpers, Line Follower etc.) do not operate when the chair is driven with the joystick.

## The Drive Wheels

The **Drive Wheels** must be engaged in order for the chair to be driven by the motors - similarly, disengaging the wheels enables the wheelchair to be pushed. To engage and disengage the wheels, pull out the red lever in the centre of the drive wheels.

The rear wheels have pneumatic tyres: keep those pumped up to the correct pressure.

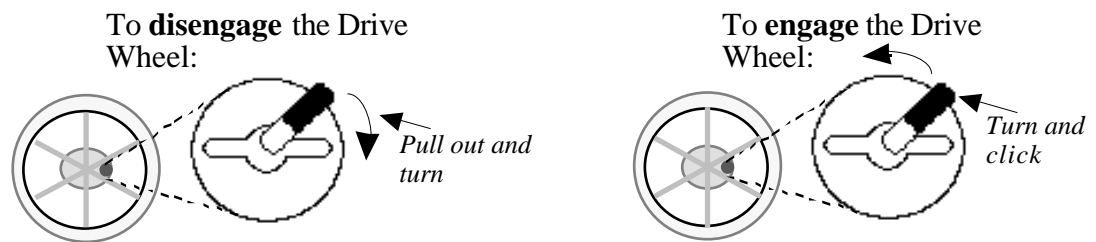

## Seating

The wheelchair seat can be removed by pressing down the two catches at the rear mounts, and tipping the seat forward and lifting it off. Putting it back is just the reverse. Make sure the rear seat latches lock the seat in position.

# Battery Charging

The battery charge level is indicated by a set of six lights at the top of the joystick.

With a fully charged battery, all six lights light up. As the battery voltage drops, the green then yellow, then red lights go out. When the two red lights only are flashing, there is approximately 10% of battery capacity left and the battery should be charged.

If the chair is used all day, every day, charge the batteries overnight, every night.

If you use the chair for short periods every day, charge it once or twice a week.

Even if you don't use the chair for a while, you should charge the batteries at least once a month.

To charge the batteries, plug the charger into the socket on the front of the joystick, then plug the charger into the mains electricity socket. **Only use the charger supplied with the chair - using a different charger may damage the batteries and/or the charger.** The batteries should be charged in a well ventilated area as the batteries may emit gas. prevent flames and sparks.

Switch on the mains and the three lights on the charger will come on briefly while the charger tests itself. The Smart Wheelchair will also switch on - if you want you can switch it off with the on/off switch on the joystick and the batteries will still charge.

The red **Mains On** lamp on the charger will light, and the yellow **Charging** indicator will light to show the battery is connected correctly and being charged. When the battery is about 80% fully charged, the Charging light will start to flash; when the green **Float/Standby** indicator comes on, the battery is fully charged and ready for use. Switch off and unplug from the mains before disconnecting the charger from the joystick.

# 3

## Smart Wheelchair Controller

### Smart Wheelchair Control Box

The Smart Wheelchair Controller is the large black unit which sits on top of the wheelchair chassis. The Control Dynamics DX Power Module (PM) that drives the motors sits underneath the Smart Controller at the rear. The Smart Wheelchair Controller contains the 'brains' of the wheelchair, together with the speech synthesiser, the switch and control connectors, and the 'ToolBox' for selecting the various wheelchair functions. A Dynamics joystick is also provided for attendant control (see section 2).

### Switching On and Off

To switch the wheelchair on, press the power button on the Joystick and select Mode 1. If the system is functioning properly, the green indicator on the joystick will be on, and the green light on the Smart Wheelchair Controller will come on. If the speech is switched on, the wheelchair will also talk. Once this has happened the Smart Wheelchair is ready to drive.

If the green light on the Smart Wheelchair Controller starts to flash when you switch on, don't panic. If the light is flashing **once** a second this means the Smart Wheelchair is in programming mode - turn programming mode off with the *Program* switch on the ToolBox. Flashing **twice** a second indicates that a bumper is stuck on, which may mean the bumpers need adjustment (see bump tools section on bumper adjustment). If after adjusting the bumpers you still get a stuck indication contact Smile Rehab. In this condition the chair will still operate but you will not be able to use the Bump Tools and they should be turned off on the ToolBox. Both of the above conditions are reported by the Speech if you have it switched on.

If the green indicator on the Joystick starts to flash when you power on it means the DX Power Module has detected a fault in the system. See Section 12 for a description of what the DX 'flash codes' mean. If a DX fault is shown, first switch the chair off, wait five seconds, and then switch on again. If it still flashes go through the trouble-shooting in section 12 and if you cannot find the fault, contact Smile Rehab.

### The chair switches itself off

The DX Power Module and joystick, and the Smart Controller are continually checking their own internal operation. If they discover anything wrong, they shut down the system, on the grounds that it is better to be safe than sorry. The red light on the Smart Wheelchair

Controller will come on and/or the green indicator on the attendant Joystick will start flashing. If this happens try switching the power on again as normal. If the chair immediately switches itself off again, go through the trouble-shooting procedure and if you cannot find the fault, contact Smile Rehab.

## ‘Ok, so what do I do now’

Setting up the Smart Wheelchair for your own particular tasks involves making some decisions. We think about tackling tasks using tools. Both of you (that is the wheelchair and you) has a bag of tools which you can choose to use for a particular task.

To make the wheelchair start, stop and change direction, the driver needs to be able to instruct and communicate with the chair - we’ve called the things to do this **User Tools** and they include switches, joysticks, computers, scanning displays, or communication aids. User tools are connected to the chair via the sockets on the front panel (for switches and Scanner), or via the ‘RS232’ socket at the back of the box.

The chair’s own sensing systems such as the bumpers and line follower are called **System Tools**. The Line Sensors plug into the front panel, while the Bumpers connect to the rear and both are set up with the switches on the **ToolBox**.

Let’s plug in a user tool first and see what happens.

# 4 Driving the chair with switches

## Types of switches

You can drive the Smart Wheelchair with almost any switch, provided it has a jack plug on the end. Switches can be operated by hand, head, finger, foot, elbow, tongue, breathing in and out, touch, sound. In most cases Smile Rehab or CALL will have recommended and supplied particular switches but as the driver's skills develop you may want to introduce new switches, or try different arrangements. This is particularly true where the Smart Wheelchair is being shared between several pilots. The chair has been specifically designed so that relatively 'non-technical' people can connect and try out different types of switches easily: to connect a switch, you simply plug it into the socket for the direction you want to move.

## Connecting switches

Ordinary single switches plug into the 3.5mm 'jack' sockets on the SwitchBox at the front of the Smart Controller. Multiple switches or switched joysticks (e.g. TASH 5-way switch, Dudley Heavy Duty joystick) connect to the 'Multiple switch' plug.

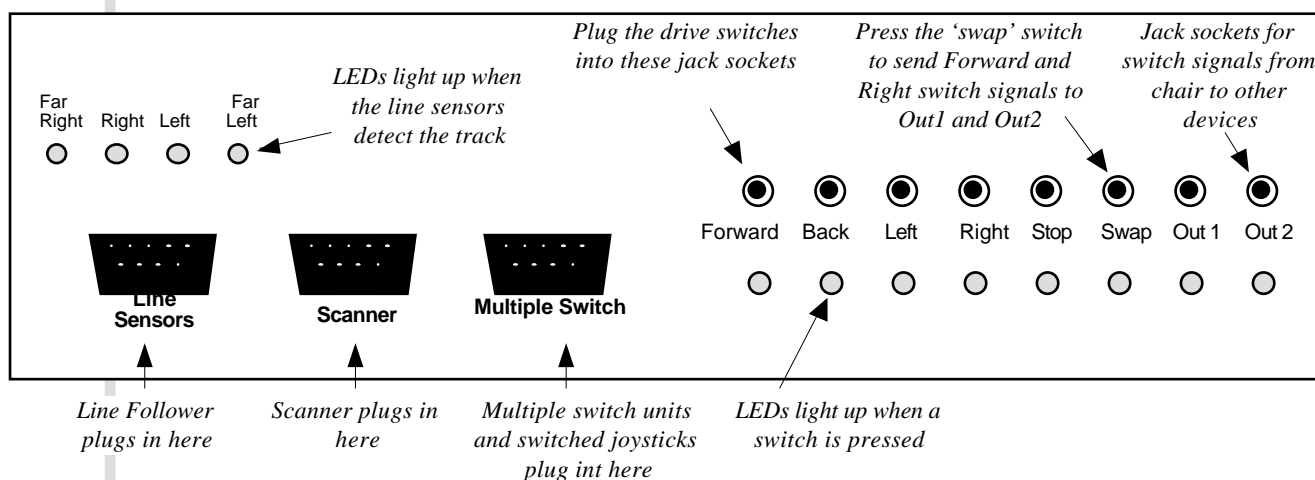

**The SwitchBox Front Panel**

Select the driving tool you want and plug it in. The wheelchair immediately knows that you have chosen the tool and will attend to its demands. So, for example, we will suppose that you want to control the wheelchair using a simple 'Buddy Button' or 'Jelly Bean' switch as a forward control. Get the switch mounted on the wheelchair in a position that will allow you to

control it and plug it in to the *Forward* socket. The wheelchair now presumes that you want to control its starting and stopping and is ready to obey you immediately.

But say all you want to do is to make the chair go and leave the chair to look after the stopping itself. This is when you choose another set of user tools to do just that, called **Motion Tools**. These are to be found on a separate box called the **ToolBox**, which we'll look at in the next section.

## Choosing switches

can be a hard, complex process. Don't expect to get it right first time. When assessing for controls for the Smart chair, we aim for a control scheme which is:

- *accurate*: ideally, the user should be able to start and stop motion accurately;
- *safe*: the switch should not be activated by accident;
- *extendible*: although you may start with only one switch, you will be hoping the user will develop use of several switches, or a scanning selector;
- *understandable*: there should be a clear link between the switch and the result, at least in the early stages. Some children with learning difficulties simply do not understand, even after lots of practice, how the small movements of a conventional proportional joystick can cause quite large movements of the chair. However, we have found that such children may learn how to drive using *separate* switches for forward, back, left or right, or using a gated, switched joystick, where the cause and effect is clearer.
- *accessible*: obviously, the control should be accessible to the driver. Less obviously, it should still be accessible when the wheelchair is moving and the driver shifting around in the seat, and ideally the rider should be able to operate the control without having to search for it.

## Switch Connectors

Single switches    3.5 mm jack sockets, Barrel 0v common, Tip signal

Multiple switch 9 pin 'D' plug	Pin	Action
	1	Forward
	2	Back
	3	Left
	4	Right
	5	Swap
	6	Stop
	7	Out 1
	8	0v common
	9	Out 2

# 5

# Smart Wheelchair ToolBox

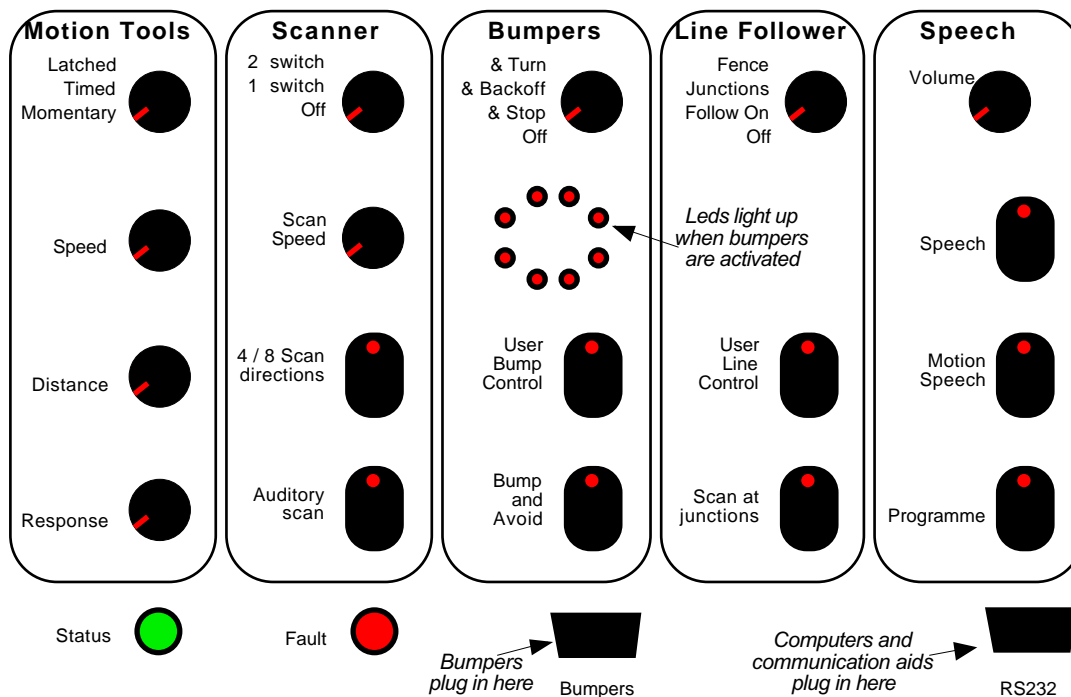

The **ToolBox** is used to make Tool selections and adjustments to the Smart Wheelchair. The function of each tool is described in the later sections of the handbook.

## Adjusting Speed

The Speed control sets the overall speeds for the Smart Wheelchair. It 'scales' all the other individual speeds (like forward/back, rotation, speed reversing from collisions etc etc). With the pointer in the middle the scale is 1, i.e. all speeds are unchanged. Fully anti-clockwise divides the speeds by 2, and fully clockwise multiplies by 2.

## Adjusting Distance

The Distance control sets the overall distances moved by the Smart Wheelchair for Timed moves, and when backing off and turning away from an obstacle. Again, it 'scales' all the individual distances. With the pointer in the middle the scale is 1, i.e. all distances are as programmed. Fully anti-clockwise divides the distances by 2, and fully clockwise multiplies by 2.

## Adjust

The Response knob adjusts the acceleration and deceleration for the Smart Wheelchair. It also 'scales' the maximum forward/backward acceleration/deceleration, and turn acceleration/deceleration. Scale the knob clockwise to multiply acceleration as programmed; turn it fully anti-clockwise to divide the response time to multiply by 2.

## Using the programme switch on the ToolBox

The Smart Wheelchair 'Speed', 'Response' and 'Distance' knobs set overall values. If you want, you can set individual quantities (for example, forward/backward speed, bump reverse distance etc) separately using the 'Programme' switch on the ToolBox. After setting these individual values, the Speed, Response and Distance knobs 'scale' them up or down. Values are remembered after you switch the power off.

The overall procedure for programming is the same whatever is being adjusted:

1. Switch Programming on - the Observer will say 'Program mode on' and the green light will flash.
2. Set Motion Tools to *Momentary*, Bump, Line and Scan Tools *off*.
3. Select the tool whose settings you want to adjust, with the appropriate Tool switch(es).
4. Adjust the setting using the Speed, Distance or Response control.
5. Press and release the appropriate switch to fix the setting.
6. Switch Programming off - synthesiser will say 'Program mode off' and the green light will go back on.
7. Turn the Tool switches and Speed, Distance and Response controls knob back to where they were before you started programming.

The sections below describe how the various parameters can be set. Often you will never need to change the standard settings, but some individuals and environments may need special control or tool arrangements. To avoid having to repeat these instructions throughout the rest of the Manual, we'll use a table like the one below to show the setting to be adjusted, the Control knob which adjusts it, the Tool switches which define it, and the switch which sets the value.

The example below shows how to set individual straightline and rotation speeds. For example, to set straightline speed, you would:

1. Turn Programming On.
2. Select Momentary motion tool.
3. Adjust the Speed knob up or down as required
4. Press and release the forward switch to fix the setting.
5. Turn Programming Off.
6. Turn all controls and tool switches back to where they were before.

The parameter to be adjusted

Which of the three Control knobs - Speed, Response or Distance - are used to set the parameter

Parameter	User Switch	Control knob	Motion Tool	Bump Tool	Line Tool	Scan Tool
Straightline speed	Forward	Speed	Momentary	None	None	None
Rotation speed	Right	Speed	Momentary	None	None	None

Press and release this switch to fix the parameter to the value set by the Control knob

Tool switch setting

*Summary table for programming Smart Wheelchair values*

## Programming Speeds

The Programming switch can be used to set straightline (forward and back) and rotation (turn left and right) speeds individually (see the table below).

Parameter	User Switch	Control knob	Motion Tool	Bump Tool	Line Tool	Scan Tool
Forward speed	Forward	Speed	Momentary	None	None	None
Back speed	Back	Speed	Momentary	None	None	None
Rotation speed	Right	Speed	Momentary	None	None	None

## Programming Veer

One of the most common problems with electric wheelchairs, particularly when driving with switches, is getting them to go in a straight line. Sticky castors, uneven weight distribution, sloping surfaces, and unbalanced motors all cause the chair to veer to left or right instead of going straight forwards. You can adjust the Smart Controller to compensate for these imbalances by using the programming switch.

Parameter	User Switch	Control knob	Motion Tool	Bump Tool	Line Tool	Scan Tool
Adjust veer	Left	Speed	Momentary	None	None	None

For veer adjustment, the Speed control acts like a 'balance' knob - set it in the mid position (12 o'clock) for zero compensation, turn anti-clockwise to make the chair veer left, and

clockwise to veer right. Press and release the *Left* switch to set the value. Test the straightline accuracy by lining the chair up on flat ground, with the castors pointing forwards, then press a forward switch. If the chair veers off within a few metres, try adjusting the veer to compensate.

## Programming Distance for 'Timed' motion

The overall Distance of the chair is set with the Distance control on the ToolBox. It scales all the individual distances by +/- 75%. Individual distances can be set using the programming switch as shown below. The maximum distance that can be set is 5m.

Parameter	User Switch	Control knob	Motion Tool	Bump Tool	Line Tool	Scan Tool
Forward distance	Forward	Distance	Timed	None	None	None
Back distance	Back	Distance	Timed	None	None	None
Rotation distance	Right	Distance	Timed	None	None	None

## Programming chair response

The overall chair response is set with the Response control on the Smart Controller. It controls the acceleration and deceleration of the chair. Turn it anticlockwise to make the chair accelerate and decelerate faster. Turn it clockwise to make it slower. Again, it scales all the other factors, from a divide-by-2 to a multiply-by-2. Individual responses can be set using the programming switch as shown below.

Parameter	User Switch	Control knob	Motion Tool	Bump Tool	Line Tool	Scan Tool
Straightline acceleration	Forward	Response	Latched	None	None	None
Straightline deceleration	Back	Response	Latched	None	None	None
Rotational acceleration	Right	Response	Latched	None	None	None
Rotational deceleration	Left	Response	Latched	None	None	None

## Programming switch response

Some people with tremor or other difficulties may hit the switch by mistake. The **input acceptance time** sets the minimum time that the switch must be held on, before the chair accepts it. Some people will hit the switch several times by mistake, after first operating it. These extra activations can be rejected by increasing the **post acceptance delay**.

Parameter	User Switch	Control knob	Motion Tool	Bump Tool	Line Tool	Scan Tool
Input acceptance time	Stop	Response	Momentary	None	None	None
Post acceptance delay	Stop	Response	Timed	None	None	None

## Resetting default values

On delivery the Smart Wheelchair comes set up with default values for all the programmable parameters. If at any time you want to reset the chair back to these default settings: switch the chair off, plug switches into the *Back* and *Stop* sockets, hold them on, then turn the chair on. The Observer will report “Resetting tools and default values”.

## Muting Tool speech feedback

You can stop the wheelchair reporting the tool selections when you make changes with the ToolBox. To do this, hold down the *Stop* switch when you turn the power on.

## Software version

Like all computer-controlled equipment, the Smart Wheelchair software program is continually being improved and developed. When a new version is completed, Smile Rehab will contact you to arrange an upgrade. To find out which version you have, hold down the *Forward* and *Stop* switches while you power up, and the speech synthesiser will tell you (provided the speech is switched on).



## Motion Tools

The rotary switch on the ToolBox labelled **Motion Tools** is used to select the switch action:

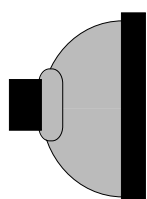

**Momentary:**

go whilst I press the button, and stop when I release it: like operating a doorbell,

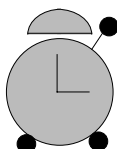

**Timed:**

go when I press the button; and keep going for a fixed time - set by the *Distance* control

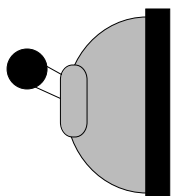

**Latched:**

go when I press the button, and stop when I press it a second time, or when I press the *Stop* switch - like turning on a house light

## Characteristics and functions of Motion Tools

### *Momentary*

Momentary control gives the majority of drivers most accurate control over starting and stopping. It also gives clear cause and effect when driving - the chair moves when the switch is pressed, and stops when the switch is released. However, momentary control does require the pilot to maintain the switch closure, and release it with good timing, so some children may find it difficult to manage, or fatiguing.

### *Timed*

Timed Control is often useful when introducing children to the Smart chair for the first time, because the child just has to activate the switch, and the chair stops itself. It lets the child gain maximum mobility for minimum effort, and once the chair is moving, the child is free to experience the movement without having to worry about stopping the chair. The disadvantage of timed control is that the driver does not have control over stopping (unless a separate switch is used, plugged into the *Stop* socket).

### ***Latched***

Latched control is for drivers who can accurately activate a switch, but cannot hold the switch on. Cause and effect of latched control is slightly more complex, since the switch has two opposite effects. We have found that few drivers use Latched turning, so we recommend that the rotation Motion Tool is re-programmed to be timed or momentary (see next section).

## Selecting separate go and turn Motion Tools

Usually, all switches use the same Motion Tool. However, it is possible to set up different motion tools for turning, than for going forward and back. For example, a useful arrangement for pilots who can only operate one switch at a time is *Latched Forward* motion, and *Momentary steering* - the driver can press the Forward switch to start moving, and then briefly press each turn switch to adjust the direction as he or she drives along.

Once the Motion Tool for turning is programmed, it stays that way until you program it to a different tool, or 'de-program' it. The Motion Tool switch then acts only on Forward/Back motion - if you program turning to be Momentary say, then it stays Momentary whether you then select Momentary, Timed, or Latched for the Forward/Back motion. If you want the Motion Tool switch to control rotational motion again, you must 'de-program' the turn Motion Tool.

Use the Programming Switch to set the turning motion tool: flick the Bump Control switch down, to *User*, hold down the *Right* switch, select the Motion Tool with the Motion Tool switch, and then release the *Right* switch.

To 'de-program' the rotation Motion Tool, switch Programming ON, set Bump Control to *User*, then press and release the *Left* switch.

(We know that setting the Bump Control switch to *User* does not make much sense, for selecting motion tools, but we have run out of options! If you have any suggestions which make more sense, please tell us!)

<b>Parameter</b>	<b>Tool Switch</b>	<b>User Switch</b>	<b>Control knob</b>	<b>Motion Tool</b>	<b>Bump Tool</b>	<b>Line Tool</b>	<b>Scan Tool</b>
Program Rotation motion tool	Bump Control set to USER	Right	-	Select Momentary, timed or latched	None	None	None
'De-program' Rotation Motion Tool	Bump Control set to USER	Left	-	-	None	None	None

# 7

## Integrating a computer or communication device to the chair

There are two ways in which you can control and integrate a laptop computer or communication aid with the Smart Wheelchair. Either you can connect the computer or VOCA to the 'RS232' socket, and drive the chair from the VOCA; or you can use the separate 'Switch output sockets' on the SwitchBox to send the switch signals to the chair, or to the VOCA.

### Using the switch output sockets

By adding an extra 'Swap' switch you can swap the signals from the *Forward* and *Right* input switches between the Smart chair, and a switch-operated computer or VOCA.

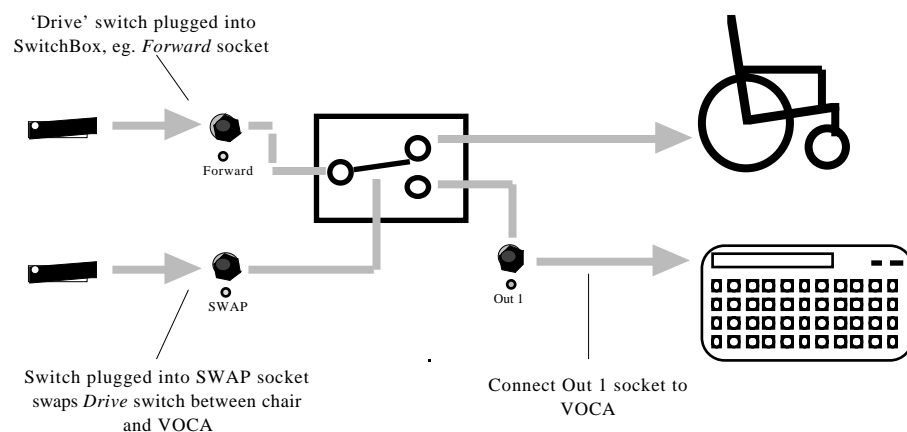

#### *Using a Swap switch to control the chair and VOCA with the same switch*

Plug your 'Swap' switch (the one you are going to use to swap the switch signals between the chair and the VOCA) into the *Swap* socket on the SwitchBox. Then plug lead(s) from the *Out 1* and/or *Out 2* sockets into the VOCA. When you press and release the *Swap* switch, the *Forward* and *Right* switches will be connected to the VOCA and operate it; when you press and release the *Swap* switch again, they will drive the chair as normal.

On pressing the *Swap* switch the speech synthesiser will report that you are using the *Out* sockets and if the Scanner is connected all the Red lights will come on. When you operate the *Swap* switch again (to drive the chair) the speech synthesiser will report this and the Scanner lights will go off.

## Driving the chair with a computer or communication aid

You can connect a laptop computer or communication aid to the Smart Controller, via the RS232 socket. This is wired up like a PC 'COM' connector as shown below, so you should be able to use a standard RS232 serial cable to connect your computer/VOCA to the chair.

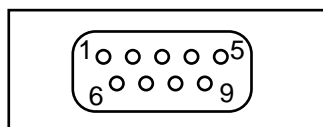

9 way D type plug

Pin 2: Rx (Input to chair)  
Pin 3: Tx (Output from chair)  
Pin 5: GND

The chair transmits and receives RS232 data at:

9600 baud, 8 data bits, 1 stop bit, no parity, with XON/XOFF handshaking.

## Sending commands to the chair

The table below gives the current set of commands which you can use to drive the Smart chair. The commands consist of letters followed by a full stop: to make the chair move forward, for example, you would send '!f.'; to stop '!s.'; and so on. We are currently adding new commands which will let you use your computer or communication aid to programme the chair to move a set distance, switch Tools on and off, and programme speeds and distances.

Command	Action
!f	move Forward
!b	move Back
!l	move Left
!r	move Right
!fl	move Forward and Right
!fr	move Forward and left
!bl	move Back and right
!br	move Back and left
!s	stop

If you want more information about driving the chair from a particular computer or communication aid, contact the CALL Centre. We can provide information on driving the chair using *Clicker* and other switch access programs on PC; using speech recognition programs; and using communication aids such as the *DynaVox*.





# 8

## Driving with the Scanner

### The Scanner box

The Scanner is a small unit with 8 pairs of Leds which correspond to each of the 8 directions the chair moves.



*Smart Wheelchair Scanner*

The Scanner must obviously be mounted so that the wheelchair driver can see it. The Scanner is supplied with a bracket for attaching it to a wheelchair tray, or it can be positioned using a proprietary mounting systems such as the Universal Switch Mount, Mighty Mount, the Slim Armstrong, the QED 'Mobilia' or Techess 'Daessy' system. Smile Rehab can supply clamps and poles if necessary. The Scanner plugs into the Scanner socket on the SwitchBox.

# Function of the Scanner and Scan LEDs

The Scanner and Scan Leds (Led stands for 'light emitting diode') do three things:

1. They can give visual confirmation of the direction the chair is currently moving (a visual 'Observer'): for example, if "forward" is selected the "forward" Led lights up. See Section 11.4 for a description of this visual feedback.
2. They can present choices of possible direction at Track Junctions, or after collisions. This is done in two ways:

For children using several switches to drive the chair directly, the available directions (say, forward and left at a line junction) light up, and the pilot presses the appropriate switch (in this example, the left or forward switch) to make a choice. Section 11.4 describes this further.

For children using one or two switches and scanning, the available choices are illuminated one at a time - and the child presses a switch when the one they want is lit. See 11.5 for how to switch on this 'Scanning Control'.

3. The Scanner can give full control over all directions of motion, for children who can only operate one or two switches. Each of the 8 directions (forward, back, left, right, and those in between - forward-right, back-left, etc) light up in turn, and the pilot selects the direction by pressing a switch. Driving with the Scanner is described in 11.5.

## Scan LEDs

Some children may find the Scanner lights too abstract for giving feedback or choices: they may have difficulty relating the forward direction, say, to the top lights on the Scanner box. The Scan Leds are separate lights which can be connected in place of the ordinary scanner. Then the lights are positioned far apart, perhaps inside large coloured cardboard arrows, so that the relationship between the light and direction is clearer.

Similarly, children using switches to drive the chair directly might find it easier to understand if the Scan Led is positioned beside, or actually inside, each control switch. Instead of the scanner, you can plug in up to eight separate Leds for each of the eight directions. In practice, you might just want to plug in four Leds and attach them to separate switches.

Separate Leds are available from Smile Rehab, or you can make up your own, according to the instructions given below.

Scanner 9 pin 'D' socket	Pin	Direction		
	1	Right	Direction, eg. pin 1	
	2	Back/right		
	3	Back		
	4	Back/left		
	5	Left		
	6	Forward/left		
	7	Forward		
	8	0v common		
	9	Forward/right		

One or two LEDs can be connected.

The LEDs are driven by a +12v source, via a 470R resistor inside the Smart Controller.

There is no need to use another resistor unless you want to use low current LEDs.

Many children will have difficulty with the concept of left and right etc, so it can be helpful to colour code the switches and Leds, and attach meaningful symbols to them. You might use:

Green switch for GO Forward

Red switch for RIGHT turn

Yellow switch for LEFT turn

Blue switch for BACK

Green, red and yellow Leds are readily available in sizes from 3mm to 20 mm (the ones in the Scanner are 10mm). Blue Leds are less common and are only available in 3 or 5mm sizes.

You can buy Leds from electronic suppliers like MPS or CPC (see Section 13).

## Visual feedback using the Scanner and Scan LEDs

### *Motion indication*

When the chair moves, the appropriate Led direction indicator lights up. This can be especially helpful with Latched Control.

### *Choices at Line Junctions*

With Bump and Choose turn, when the chair hits an obstacle to the front, it stops, and will not let you go forward again - only

The Scanner or Scan Leds indicate the left, right, or back Leds. The pilot uses the switches to drive off in any of these directions. Similarly, choices to turn with Bump and Choose turn are given using the Scanner/Scan Leds.

### *Choices at Line Junctions*

If the chair finds a line junction, say to the left, it stops and lights up the left and forward Leds to indicate these are the possible choices. The driver presses the left or the forward switch to choose the track to follow.

**Note:** here, we are talking about using the Leds to reinforce choices, for children using *several* switches to drive the chair *directly*. If you want these choices to be *scanned*, see below.

# Scanner Tools

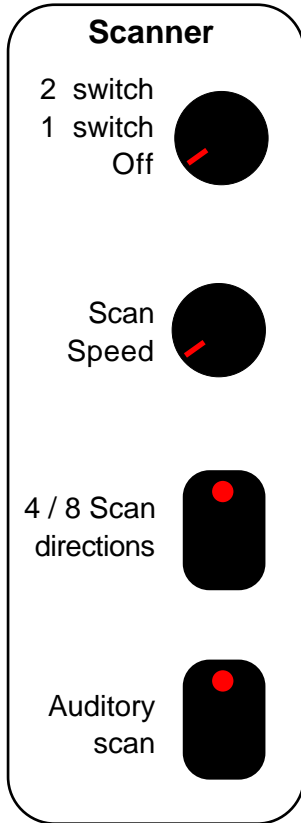

Use the Scan Tools controls on the ToolBox to select scanning control and either one or two switch scan.

The Scan speed can be altered with the speed control.

The scanner can either scan through 4 or 8 directions.

And choices can be offered using speech, as well as with the Scanner lights.

## One switch scan

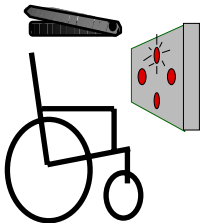

Plug your 'Drive' switch into the *Forward* socket. Press and release the switch to start the scan, then press the switch when the required direction lights. The chosen direction will stay on while the chair is moving (according to the motion tool chosen). When the chair stops, press the switch to start the Scanner again at the beginning. If no direction is selected after 3 cycles round, the scanner stops until the switch is pressed again. The Scan Speed and number of scan cycles are adjustable (see below).

## Two switch scan

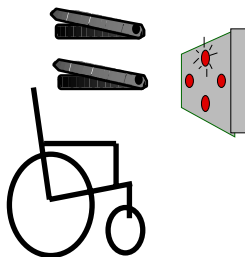

Plug the 'Drive' switch into the *Forward* socket, and the 'Scan' switch into the *Right* socket. Press and release the Scan switch to light up each direction in turn until you get the one you want, then press the Drive switch to move in that direction. If the Scan switch is held down, the Scanner scans at the speed set by the Scan Speed control. Movement is controlled with the selected Motion Tool.

## 4 / 8 direction scan

8

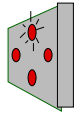

4

You can scan either 4 or 8 directions.

### 4 directions

Pilots who need a slow scan speed may choose to select from 4 rather than 8 directions.

### 8 directions

Driving with 8 directions is much easier than with only 4, provided the pilot can control the Scanner accurately.

## Smart Scan

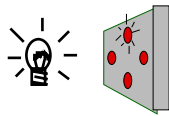

This scanning approach is for good scanning users and gives them better control of the chair as they are driving.

With both the Latched and Timed modes, moving forward or back the driver is offered momentary control. The nudge left/right are on momentary control and stops when you release the switch.

## Auditory scan

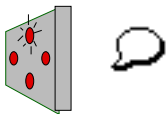

With auditory scan, the speech synthesiser will speak out the choices as they are offered. This can be helpful for visually impaired pilots, or to help teach driving direction vocabulary.

## Setting Scan speed

The scan speed is set by turning the Scan speed knob on the Toolbox.

## Setting number of scan cycles

This setting controls the number of times the scanner cycles round, before it stops and waits for another switch press. Use the Programming Switch, set Single Switch Scan, turn the Scan Speed knob to select the number of Scan Cycles, then press and release the *Right* switch.

Parameter	User Switch	Control knob	Motion Tool	Bump Tool	Line Tool	Scan Tool
Number of scan cycles	Right	-	-	None	None	Single Switch Scan and set cycles with Scan Speed control

## Three-switch scan

Three switch scan operates like two-switch, except that a third switch plugged into *Left* lets the driver scan anti-clockwise as well as clockwise.

### Three Switch Smart scan

With three switch Smart Scan, the two turn switches act like momentary turn switches if the chair is moving but if it is stopped, they scan the display. It's a lot more intuitive than it sounds and control. To turn Three Switch Smart Scan on or off, use the Programming Double Switch scan and set Smart Scan ON, press and release the *Forward* or the *Back* Switch to turn it off, then switch Programming off.

Parameter	User Switch	Control knob	Tool	Line Tool	Scan Tool
3 switch Smart Scan ON	Forward	-	-	None	Double Switch and Smart Scan ON
3 switch Smart Scan OFF	Back	-	-	None	Double Switch and Smart Scan ON

## Bump Tools

Suppose now that you want to delegate the responsibility for dealing with impacts to the wheelchair itself, leaving you with just the task of deciding when to go or stop. The wheelchair tools to do that are called **Bump Tools**.

The Bump detectors are mounted all round the chair. Separate sensors at front, back and sides let the chair sense the location of the obstacle. The Bumpers plug into the ‘Bumper’ socket on the back of the Smart Controller. The bumpers are rubber tubes connected to pressure switches: when the chair hits something, the tube is squashed and the air inside operates the pressure switch.

The Bump sensors do not make the chair completely safe: it is physically impossible to spot a 60 kg. wheelchair, plus rider, moving even quite slowly, before the rubber compresses and the metal bumpers contact.

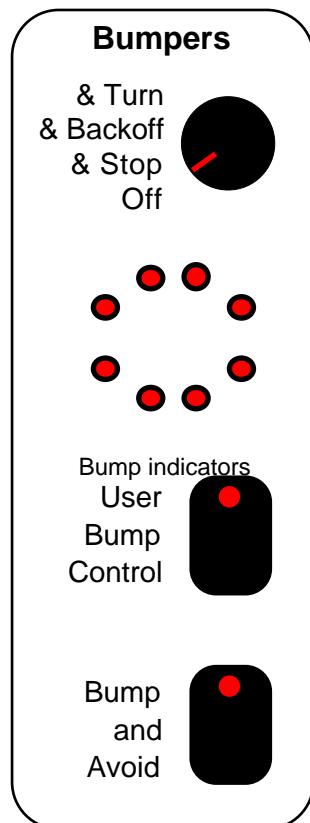

Bump Tools allow the user to let the chair deal with any obstacle that might cross its path, while the user is able to concentrate on making it go. Bump Tools can be used by independent drivers to help protect the user and environment (*Bump and Stop*), to help get out of trouble after a collision (*Bump and Back Off* or *Bump and Avoid*), or to give a crude means of exploration and play (*Bump and Turn*).

There are several different bump tools, all selected using the ToolBox.

## No Bump

The chair will do nothing on colliding with an object

## Bump and Stop



Recognises that the chair has collided with an object, stops the motors and waits for you to press go again. If you try to keep going at the object, the chair will not let you - it knows that there is an obstacle in your way and will only let you move off in a different direction. Bump and Stop is essentially a safety system.

## Bump and Backoff

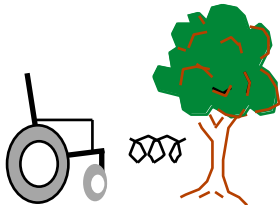

Recognises that the chair has collided with an object, stops the motors and backs away from the obstruction. Useful for pilots who can drive and steer, but need a little help to get out of tight corners.

## Bump and Turn

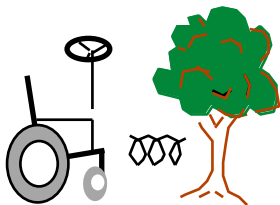

Recognises that the chair has collided with an object, stops the motors, backs away slightly and turns the chair through a small angle to allow you to go off in another direction. The direction of the turn (left or right) is set up with the ToolBox programming switch. Bump and Turn is useful to introduce steering; play games; and for a single switch user to explore.

## Bump and Choose Turn

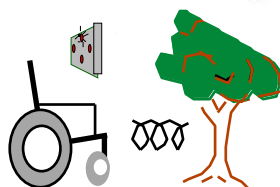

Bump and Choose Turn, offers choices to the user over which direction to go after a bump. Bump and Turn must be selected on the ToolBox for this tool to be on. Program Bump and Turn for choices the following programming must be carried out.

Not available yet

Parameter	Tool Switch	User Switch	Control knob	Motion Tool	Bump Tool	Line Tool	Scan Tool
Scanning Bump Choices ON	-	Forward	-	-	Bump and Turn ON	None	Single / Double Scan
Scanning Bump Choices OFF	-	Back	-	-	Bump and Turn ON	None	Single / Double Scan

## Bump

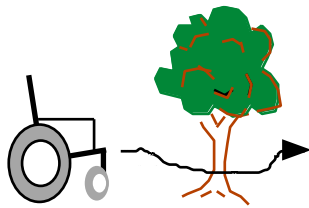

Standard Bump Tools are very simple and easy to understand, and are good for games and early exploration.

Avoid is for pilots who want slightly better control. If the chair is going forward, say, and something to the left or right, the Tool will turn the chair away to avoid the obstacle. If the chair hits the obstacle and the chair decides it can't be avoided, the selected Bump Tool (Bump and Stop, or Bump and Turn ON) will be used.

## User / Chair Bump Control

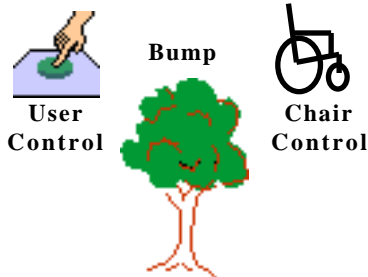

The selected Bump Tools can operate under User or Chair control.

**Chair Control:** the selected Bump Tool operates automatically, i.e. for Bump and Turn it reverses and then turns by itself. The chair ignores any commands from the user while it is manoeuvring.

**User Control:** the distance reversed and/or turned is controlled by the user's switch, with whatever Motion Tool is selected. This gives better mobility, provided the pilot can control the backoff and turn distances accurately.

## Programming the Bump parameters

The speed and distance or angle moved with the Bump Tools can be adjusted with the Speed and Distance controls. They can also be set individually - see below.

Parameter	User Switch	Control knob	Motion Tool	Bump Tool	Line Tool	Scan Tool
Bump reverse speed	Forward	Speed	Momentary	Bump & Backoff	None	None
Bump turn speed	Right	Speed	Momentary	Bump & Backoff	None	None
Bump reverse distance	Forward	Distance	Timed	Bump & Turn	None	None
Bump turn distance	Right	Distance	Timed	Bump & Turn	None	None
Bump turn to left	Left	-	Momentary	Bump & Turn	None	None
Bump turn to right	Right	-	Momentary	Bump & Turn	None	None

## Bumper fault finding and adjusting sensitivity

The bumpers are designed to take a lot of punishment but sometimes faults can develop. The operation of the bumpers can be checked by monitoring the bump indicators on the Smart Wheelchair ToolBox panel.

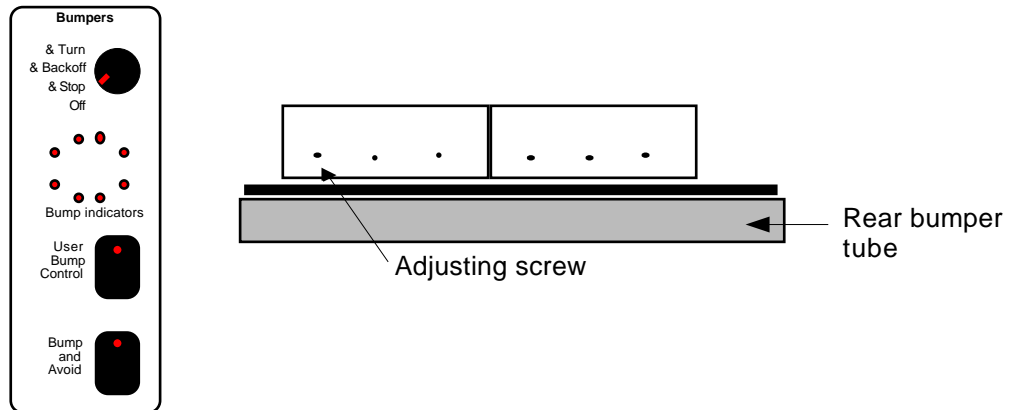

### Bumper sensors

When a bumper detects an object the indicator light up. If you think one of the bumpers is not working you can test it by pressing the area you think is faulty and check the indicator comes on. Another possible fault is where a bumper is stuck on - the indicator is on all the time. If there is this type of fault the Smart Wheelchair will detect it when you power on, and report it using the speech synthesiser.

If the Bumpers do not come on, or are stuck on, you can try and adjust the sensors by inserting a small screwdriver into the adjustment holes and turning the adjusting screws clockwise or anti-clockwise. If the fault is a non-working bumper try turning the screw clockwise until the indicator comes on all the time. Once you have reached this point turn the screw anti-clockwise about a quarter turn and check to see if the bumper works. If you can't adjust the bumpers so that they operate correctly, contact Smile Rehab.

If the bumper is stuck on, follow the same procedure except this time you turn the screw anti-clockwise until the indicator goes off. If the indicator doesn't go off contact Smile Rehab for help.

If you have successfully managed to adjust the bumpers, try making small adjustments to the bumper so that the indicator comes on for about one to two seconds when a bump is detected.

## Line Follower Tools

The Line Follower system also provides the chair with a number of different “tools”.

**None**

The chair ignores any tape it sees on the floor.

**Line Following On**



With Line Following turned on the chair will follow track on the ground. In this mode the chair will ignore any junctions it finds.

If you want short sections of track for guiding the chair through doorways or tight spaces this is the tool to choose.

**Line Following with Junctions**



This tool lets the chair follow the tape track laid on the floor, perhaps around home, between rooms in school, or around the classroom. When a junction is found, the driver selects the track to be followed by pressing the appropriate switch (i.e. left, right, forward or back), or by selecting from the choices offered visually or aurally by the Scanner and Observer.

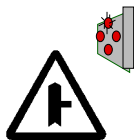

When Control is switched off, choices at line junctions are presented simultaneously: e.g. forward and left lights up at the same time, even if they are driving the chair directly with the Scanner. It may be easier if they are offered only one choice at a time. Some children may be driving with a single switch, but if they come to a Right turn junction they don't have a *Right* turn choice. This lets the pilot control the chair but offers a choice of scanning.

Not available yet - junctions are always scanned

## Safety fence



The chair stops when it detects a line. Tapes can be laid around dangerous features like stairwells, to stop the chair reaching them. The safety fence can work just like bumpers by programming i.e. whatever the bump tool is set to when the chair detects a line it will treat it as a bump or it can work independently of the bump tool and just stop the chair.

The programming for the sa.

Parameter	User Switch	Control knob	Bump Tool	Line Tool	Scan Tool
Safety with bump ON	Forward	-	Momentary	Safety	None
Safety only	Forward	-	Momentary	Safety	None

## User / chair Line Control



Line Follower



**User Control:** if the pilot wants to turn off the line at any point, s/he simply turns to the right or left until the chair is free of the line. Then the chair stops and says “Lost Line”.

**Chair Control:** any instructions to turn off the line are ignored.

## Line Follower accuracy

When following a track, the chair speed is limited to give reasonable accuracy. The speed can be turned down below this maximum value, and it is also possible to change the ‘sensitivity’ and ‘damping’ of the line follower. If the chair seems to waver when following the line, try turning the speed down a little. Heavier users may need the line following speed increased a little. Note that the chair will always follow the line at the set speed - turning the *Speed* knob on the Smart Controller only effects the speed away from the line and has no effect when line following.

**NOTE: The Line Sensitivity is there to let us adjust the Line Follower to different types of wheelchair - don’t adjust it unless you’re sure you really need to!**

<b>Parameter</b>	<b>User Switch</b>	<b>Control knob</b>	<b>Motion Tool</b>	<b>Bump Tool</b>	<b>Line Tool</b>	<b>Scan Tool</b>
Line following speed	Forward	Speed	Momentary	None	LineFollow On	None
Line following sensitivity	Right	Speed	Momentary	None	LineFollow On	None

### *Programming the Line Speed*

## Line Follower box and tape

The Line Follower is a black box mounted on the front of the chair, with infra-red sensors which detect retroreflective tape. The sensors work regardless of background light and don't care whether the line is on dark or light floor coverings, whether carpet or lino. Their function is to detect where the line is in relation to the chair so that the chair can follow it. If the middle two sensors 'see' the tape, the chair goes straight. If sensors to left or right come on, the chair adjusts the heading to try and get back on line.

50 yards of tape is supplied with the chair and more tape can be ordered from Smile Rehab.

The Line Detector plugs into the connector on the front of the Smart Wheelchair Controller. Switch the power off before you connect the line follower.

## Who might use a Line Follower?

The line follower might be considered for several reasons and for several groups of children.

First, if a child has learning difficulties, then using the chair with or without collision sensors may be too complex to understand: in order to move around the child must have an idea of where they wish to go, of the sequence of movements that will take them there, and the ability to correct this plan if unexpected events like obstacles are encountered. A line follower is much simpler to operate: the child just needs to know that if he or she presses the switch, the destination will be reached (assuming that the line goes somewhere interesting and the child knows that).

A second use might be to motivate a child who seems unexcited by the wheelchair and bump tools, possibly again for cognitive reasons. One of the reasons for the child's lack of interest may be that he or she doesn't connect the simple movements of the chair with going anywhere useful or interesting - the basic understanding of the use of mobility is not there. By pressing the switch and travelling around, the usefulness, and hopefully motivation, of mobility are experienced with the minimum of cognitive, physical and perceptual demands on the pilot.

A third group are those children who have very limited physical control skills: single switch

users, possibly with unreliable control over a second switch. Again, while bump tools offer exploration in unstructured environments and limited functional mobility in structured environments, a line follower enables the child to move from place to place without the need for supervision.

The final potential user group are pilots who do have good control skills, but suffer from fatigue and cannot maintain a high level of control for long periods. They could use the line follower like a bus, which can be joined and left at any point, to reduce the effort involved in moving around.

***Discussion: a comparison between Line Follower and Bump Tools***

It should be clear that the line follower has quite different uses compared to the bump tools. Line following can provide a means of independent functional mobility for quite severely disabled children who might find the bump tools too challenging. *Bump & Stop* and *Bump & Reverse* are mainly safety tools: usually, the pilot will be reasonably capable of moving, stopping and steering. *Bump & Turn* provides exploration in a different sense to the line follower, and functional mobility for single switch users in certain situations such as games but again requires the user to have an idea of where and why they want to move. The line follower makes fewer demands on children's physical, cognitive and perceptual skills and so can be used by more severely disabled children. It provides a complementary set of experiences to the bump tools: while the bump tools give the child quite direct control of movement - moving for the sake of moving because the actual motion and collision is fun, the line follower takes more of the load and gives experience of mobility as a skill for moving around to where you want to be.

Expanding these ideas a little further, we might class bump tools as get-you-out-of-trouble; Sonar Bump tools (using the experimental obstacle detection system which is still in development) as help-prevent-you-getting-into-trouble; and line follower as stop-you-getting-into-trouble-in-the-first-place; with corresponding implications for control demands and learning experiences.

There is consequently a danger that in relying on the line follower the child will not have a chance of developing or learning new skills. With the bump tools and motion tools, we have an expectation that children will develop new skills and a "path" to get them there (start off with one switch, add another, then a third, and so on).

Lastly, bump tools (particularly bump and turn) often require supervision from adults since they do not prevent pilots getting stuck in corners completely whereas a child should be able to follow the line from one place to another and have reasonable confidence of getting there, thereby giving experience of successful mobility without help from others.

## Finding the line

The line follower has no effect on the chair's motion until it finds a line to follow. If a line is detected under the chair it will stop and say "Found line". If you want to follow the line, press *Forward*. If you don't, steer away from it until it says "Lost line". Generally the chair follows the line in the direction you approached it, but sometimes it might get it wrong and try to move in the opposite direction (see the diagram below). Also, if you travel up to the line very quickly, you may overshoot it before the chair stops - this should not be a problem because the chair will remember where it saw the line and turn towards it, but occasionally it might miss and the chair will say "Lost line" and you'll have to reverse back to it until it says "Found line". If you cross the line very fast, the sensors may not see the track at all - but most line follower users will not be driving that fast.

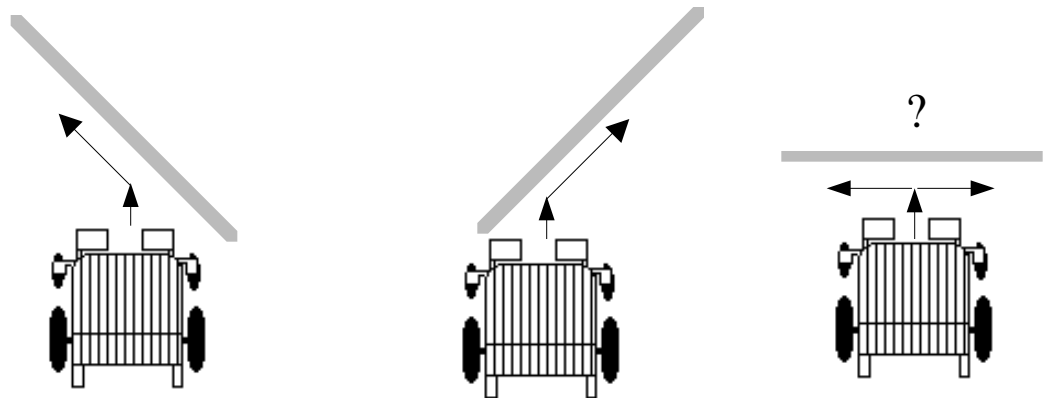

*Finding and joining a line*

## Following the line

The key fact to remember is that once the chair has found the line it will follow it unless a) you tell it to leave by steering off or b) the chair runs straight off the end of it (as for leaving a doorway funnel). Once on the line, the chair moves at a limited speed while told to go forward (or reverse - the chair will also follow the line backwards but not very well - like an articulated truck reversing with a drunk driver). The Line Follower works with the motion tools as you would expect: momentary, timed and latched. It also works with the bump tools, although inevitably it changes the way they work a little. With bump and stop, the chair will stop on collision and allow you to back off or turn. If you reverse, the chair will go back along the line. If you turn, it will leave the line. With bump and backoff it will stop and reverse back along the line. With bump and turn it will stop, back along the line and then try to turn off it: whether it succeeds depends on the angle of turn you've set.

## Leaving the line

If the chair is following the line and the line suddenly stops, it will stop and say “Lost Line”. The user can either try to find it again by turning around or go straight on and leave it behind. If Line User Control is on, the pilot can also leave the line at any point just by turning off it. If Line User Control is off, the chair will ignore any instructions to turn right or left off the line.

## Line Junctions

The Line Follower will detect junctions like the ones below, stop, and offer a choice using the Observer and/or Scanner about which track to take. The pilot presses any switch to select a line, and the chair will move on to the correct track, and then stop and wait for a new command. If you don't want the chair to offer choices at junctions, select the line following tool and it will just carry straight on and ignore the junction.

## Laying out a line

### *Line Follower Tape*

The tape is quite sticky and reasonably robust. Before sticking it down permanently, it's best to lay it on the floor and try out the chair along it. It might also be worth while sticking the tape down for a few days with sellotape, blue tac or velcro until you're sure about the position. As well as being annoying if you stick it down in the wrong place, it's also quite expensive. Give some thought to where you want the tape to go before you start laying.

### *Corners*

The line tape consists of straight and corner sections. When laying through tight gaps, keep in mind the obvious, like the width of the chair. You can make the corners as tight as you want and the chair will try to follow them, but if you make them too tight it will swing out from the tape and not follow it accurately - it will still get there in the end, but not exactly on top of the line. It's best to try and lay corners no tighter than the one shown below.

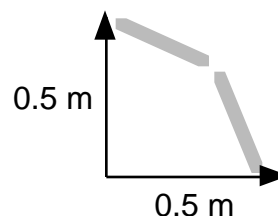

*Suitable corner section made up of two segments*

### *Line Follower ‘circuits’*

In a classroom, you might want a circuit of the room taking in various interesting “stations”. These stations can be activity areas, or different floor materials such as knobby man-hole cover type things, ramps, grids, or pressure pad switches connected to Mains Switchers, Big Macks or toys.

In the school generally, try to arrange circuits rather than single lines - note that you can have the line going along corridors and into loops in rooms. You can make sure the chair follows the line round the loop consistently (assuming you don’t want to choose at junctions) by using layout (a) below because the chair tends to follow the path it is currently on. Occasionally you might find the chair following the loop the wrong way round. If you don’t care which way round the loop the chair should go, make the loop symmetrical (layout (b)).

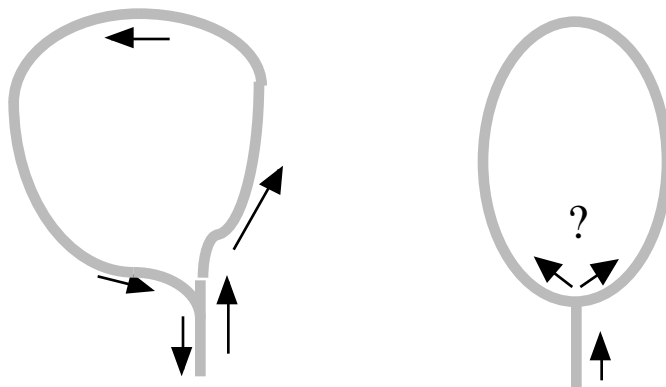

(a) *Laying loops round a room* (b)

For crossings where you have the Doorway Funnel on, **and you want the chair to ignore the junction**, layout (a) shown below works best. If the two lines cross at an acute angle there is a danger that the chair will follow the wrong one (b).

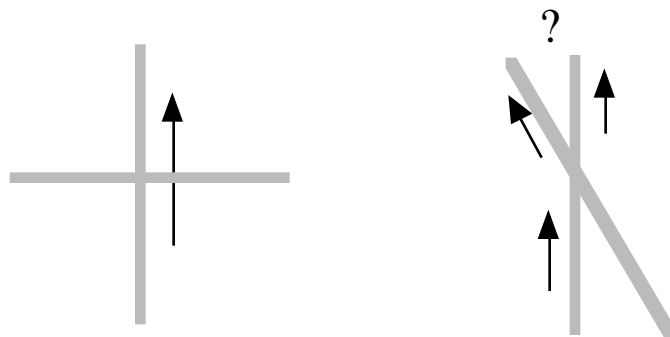

*The ideal line crossing* (a)

*A potentially confusing crossing* (b)

### ***Line Junctions***

The chair recognises a junction when three or more of the sensors see tape. To detect a junction, the chair must be following the line reasonably accurately, without weaving, otherwise it might miss the junction.

Here's how it works. If the chair is accurately tracking the track, the middle two sensors are on. If the far right sensor detects tape as well, the chair stops, nudges forward a bit and then has another look. If it can still see the line it offers *Forward* or *Right*. If there is no line going forward it assumes that it has found a 'T' or 'Y' junction.

When you have the junction tool on, and you want the chair to detect a junction, it helps the chair recognise it if you have a small piece of tape 'leading in' to the junction.

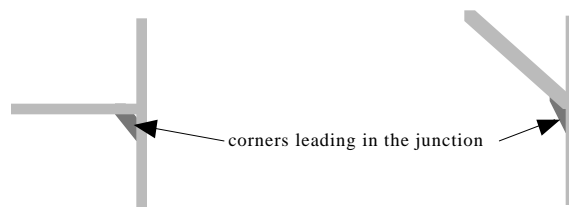

*Leading into line junctions*

The chair recognises junction types (a) to (f) below, but the most reliable type is the 'T' (e) or 'Y' (f).

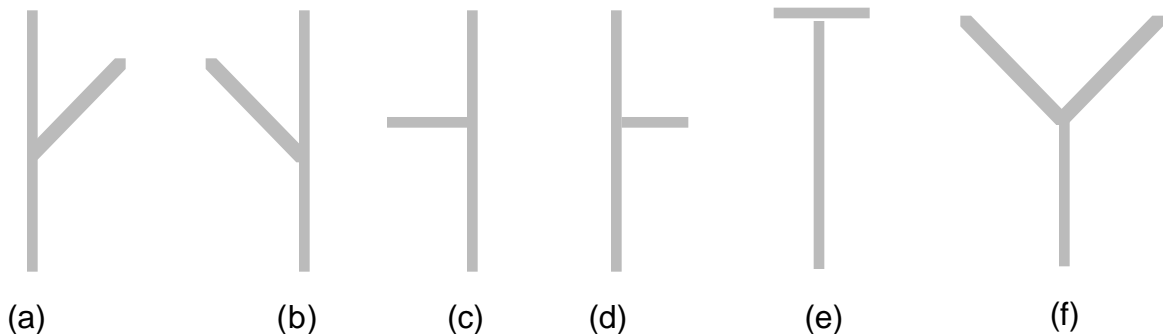

At the moment, it will not reliably recognise a cross-road (g) - if you need a crossroads, try staggering the junctions so you have a left, then a right junction in succession (h).

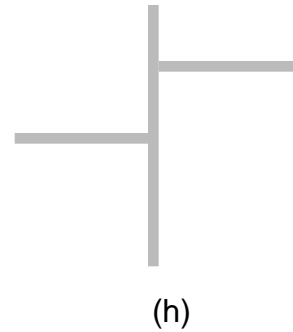
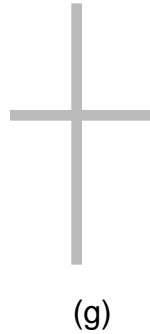

*Use staggered junctions (h) instead of crossroads (g)*

If you are laying out a track where you want pupils to choose at junctions in all three directions try and use 'T' or 'Y' junctions. At the moment the chair will recognise the junction when going from right to left (a), but may not recognise it properly when going from left to right (b) or when joining the main line from the 'spur' (c). Sometimes it will offer *Left* or *Right* and sometimes it will go straight on following the line. Use 'T' or 'Y' junctions to get a consistent response.

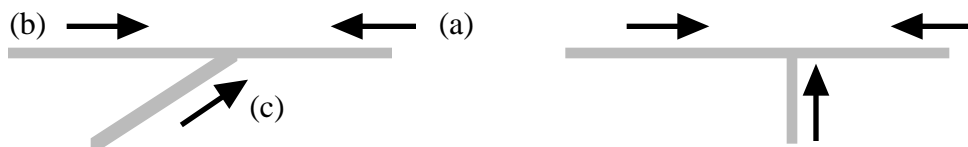

*Use 'T' or 'Y' junctions where chairs are coming from all three directions*

## Who might use a doorway funnel?

Some pilots have full (using three or four switches, a joystick or communication aid) but erratic control over the chair and find it difficult to get through tight or awkward spaces such as doorways. For these children, some help in negotiating these contexts would increase independence and reduce frustration. We know that Bump tools can help a little, but often they help too late due to the sharp irregularities of doors. Using a line follower section should solve the problem almost completely if the line is laid to give clearance of the sides of the doorjamb or obstacle.

## Using the doorway funnel

The basic doorway funnel layout is given below. The user drives up to the line and doesn't have to be too careful about accuracy provided the chair goes over the line. When the chair detects it, it will stop and say "Line found". The pilot then presses *Forward* and the chair will follow the line through the doorway until it reaches the end of the straight piece, when it will stop and say "Line Lost", leaving the pilot to move on. Note that the user can leave the line at any point by turning off it (provided Line Control is set to User).

The Doorway Funnel is not clairvoyant and so may occasionally get it wrong. For example, if you approach the capture funnel at a really extreme angle the chair might follow the line in the wrong direction.

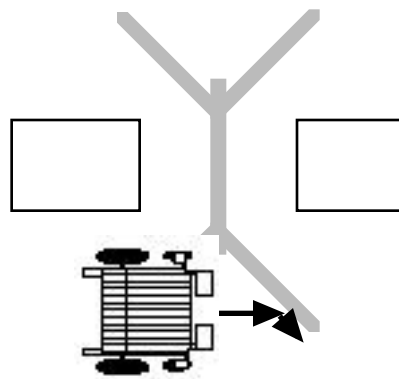

*Joining the funnel at an acute angle*

If you approach the line very fast there is a small but finite possibility that the chair will overshoot the line and lose it, although this is unlikely since the chair remembers where it last saw the line and should turn towards it. It is also possible for the chair to join one side of the funnel and when it comes to the neck, to follow the *other* side of the funnel rather than the neck. To avoid this, "stagger" the two funnel sides where they join the neck.

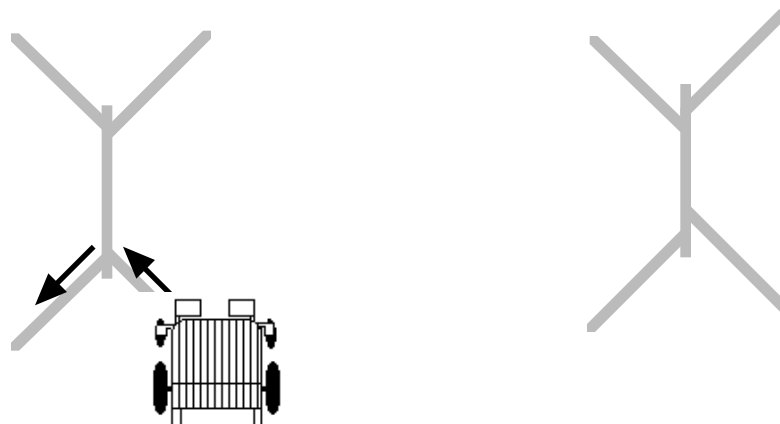

*Chair follows other funnel instead of neck...*

*avoided by staggered funnels*

## Laying tape for a doorway funnel

Key features of a successful funnel are sufficient width to capture all the traffic approaching the door, and sufficient clearance in front of the door to stop and turn speed freaks before they hit the wall. The angle of the funnel is not particularly important, although the shallower the angle the tighter the chair has to turn:  $45^\circ$  is probably a good compromise. Note that the funnel joins the neck a little from its end: this “tail” is needed so that when the chair goes through the neck to the far side, it carries straight on until the line is lost. If the tail was not there, the chair would try to follow one of the funnel sides on the way out.

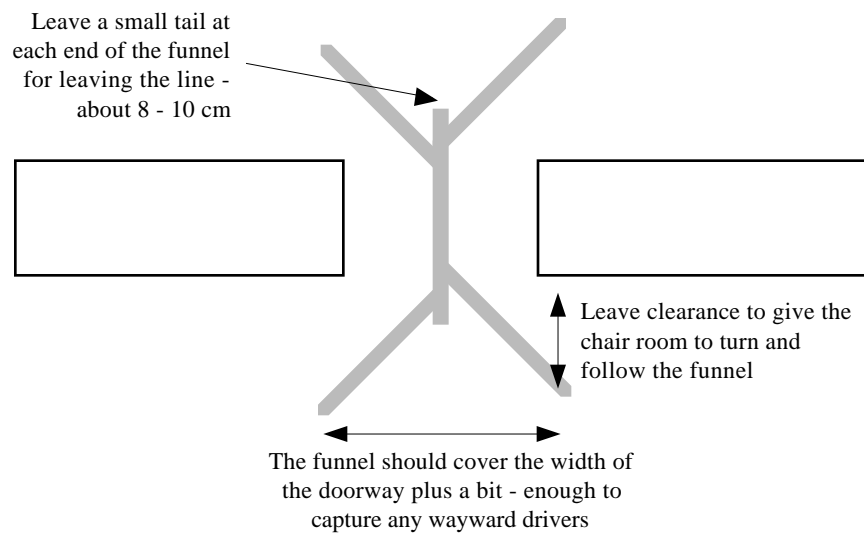



# Observer Speech Tool

You are now armed with a set of tools that can allow you to drive your wheelchair while delegating other responsibilities to the chair, but that can leave you with a problem: how do you know when you're in control of the chair, and when the chair has taken over the control itself? For example, you have your switch plugged into *Forwards; Timed* tool selected and *Bump and Turn* on. You bump into something and your chair stops, backs off and turns - who's done what?

The Smart Wheelchair has a tool which watches the operation of the chair and reports back using a speech synthesiser - we call it the **Observer**. The Observer will tell you when certain events occur, for example "Oops, I have hit something!", when a Bump occurs; "Found line" when a line is encountered; or "I am going forwards", when a forward command is given. The Observer also uses the Scanner lights to give choices and indicate options.

There are several other reasons why we might want this facility:

- to provide reinforcing feedback when a user is learning to use the system. In the early stages of use, this is very helpful in explaining the chair's actions to a new user;
- as a first introduction to communication using an artificial voice;
- to encourage communication using voice output, by choosing functionally useful communicative contexts and messages, i.e. so that the user communicates not by selecting from a display (although this would be the eventual aim), but by driving the chair into the situations where the messages are generated;
- as a warning that the chair is moving - for example, if there are children with a visual impairment, and/or learning difficulties nearby.

The table below gives some currently stored contexts and messages.

<u>Context and Event</u>	<u>Message</u>
Forward	"I am going forwards"
Back	"I am going back"
Left	"I am turning left"
Right	"I am turning right"
Stop	"I am stopping"
Bump and Stop	"Oops, I have hit something"
Bump and Reverse	"Oops, I have hit something. I'll try to back off."
Bump and Turn	"Oops, I have hit something I'll try to back off and turn left"
Encountering line	"Found Line"
Leaving line	"Lost Line"

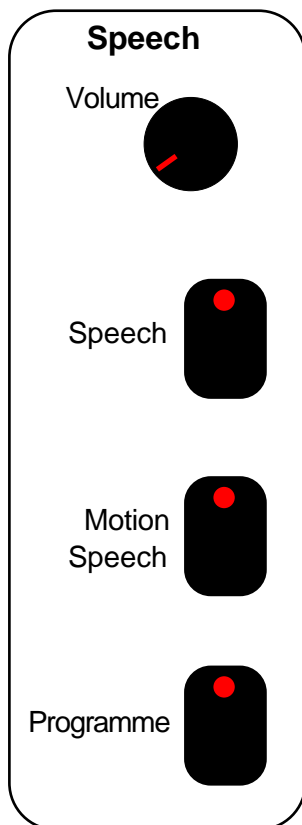

The volume knob sets the speech volume.

The speech can be turned off completely by pressing the *Speech* switch on the ToolBox.

Certain Observer messages can be turned on or off depending on what you require or how annoying they get. The motion speech can be turned off with the *Motion Speech* switch on the ToolBox so the chair won't say 'I am going forward', 'I am stopping' etc but will still report collisions or finding the line.

The Programme switch is used to set speeds and distances - use it with care, and refer to Section 5 before you change anything.

The Observer also reports which tools have been selected when you turn on or when you change them. This can be turned off by holding the *Stop* switch down when you power the chair on. When you change tool settings, the Observer won't report it. To turn this reporting on again switch off and hold the *Stop* switch down again as you turn the chair on..

## Maintenance

All the normal practices employed in looking after an electric wheelchair apply to the Smart Wheelchair.

### General

1. The tyre pressure should be checked regularly. The recommended pressure is 35 p.s.i. If tyres are not correctly inflated, the performance and stability of the chair may be effected.
2. The battery charge should be checked before and after every session and if necessary, the batteries charged.
3. Any loose bolts or fasteners should be tightened.
4. The chair should be kept clean and free from grease and dirt.
5. Battery terminals must be kept clean, tight and coated with petroleum jelly (Vaseline).

### Electronic components

1. The DX System and Smart Controller should be regularly checked for integrity. Loose, damaged or corroded connectors or terminals, or damaged cabling should be replaced.
2. All switchable functions on the DX System should be regularly tested to ensure they function correctly.
3. All system components should be kept free of dust, dirt and liquids. If necessary wipe with a cloth dampened with warm water or alcohol. Do not use solvents or abrasive cleaners.
4. Where any doubt exists, consult Smile Rehab.
5. There are no user-serviceable parts in any DX System or Smart Wheelchair component - do not attempt to open any case.
6. Warning : If any DX or Smart Wheelchair component is damaged in any way, or if internal damage may have occurred (for example by being dropped), have it checked by qualified personnel before operating the chair.

# Safety warnings

You must read and understand all the warnings throughout this handbook and heed them - if in doubt ask Smile Rehab for advice.

## Supervision

Most Smart Wheelchair users will not be able to fully control the chair independently and safely - if they could, they would not need a Smart Wheelchair. Although the bumpers, line follower and other systems will assist the user, **they cannot prevent collisions happening**. Therefore, the Smart Wheelchair pilot should always be supervised by a competent assistant who can stop the chair in potentially unsafe situations.

## The Wheelchair must not be operated

- near ponds, lakes or other water masses.
- near roads.
- on steep or slippery slopes.
- near fires or similar hazards (such as chemical or electrical laboratories, or where heavy machinery is in use).

The Smart Wheelchair is an indoor chair. It may be also be used outside but **only** on flat, even and firm surfaces such as concrete or paved paths and patios. **Do not** attempt to use the chair outdoors on rough, uneven or inclined surfaces or on grass.

## In case of fire

### ***First Preference is to move the child and chair***

The procedure is

- switch off
- unlock the rear wheels
- push the chair out of danger.

### ***Second preference is to remove the child***

Unstrapping might take longer, but there are situations when the chair could not be pushed over obstacles.

## **General use**

*Treat the chair driver as you would a very young child, thinking of all the hazards that might confront him or her*

1. Make sure the driver is always securely strapped into the chair when s/he is using it.
2. Always fit the driver's seat securely to the chassis, with the locking catches engaged.
3. Do not let the driver operate the chair in the close vicinity of stairs either inside or out.
4. Do not allow the child to drive alone in a room with a fire, or to drive too close to a fire. Be careful too of wall heaters - the driver may have decreased sensation and not know when he is burning.
5. Be especially careful of the driver in the kitchen. Again, think of all the hazards that you would be wary of with a young child.
6. Do not encourage the child to use people to bump into, as the child may have little appreciation of pain.
7. Be careful of flexes - their height could be a potential hazard to a child in a wheelchair - you can duck, but they can't! Also, because the child driver could pull electrical things on top of them.
8. Be very careful of tables - the bumpers will only stop the chair if they make contact with the table leg, and the table is heavy or fixed to the floor or wall. Lightweight items of furniture will be pushed across the room without activating the bumpers.
9. Switch off the power and engage the rear wheels before entering or leaving the chair.
10. Do not stand on the foot plates or bumpers when entering or leaving the chair.
11. Do not hand heavy objects on the back of the seat that could cause the chair to become unstable, particularly when negotiating inclines.

## **Emergency stop**

- Stopping/ Shutting down fast - use the OFF switch.

## **Weight and lifting**

1. Do not try to lift the chair unless absolutely necessary - it is very heavy. If you must lift it, get help from other people.
2. Lift it by the steel bumper or bumper supports, not by the rubber bumper tubing. Do not try to lift the chair by holding on to the Smart Controller, joystick, switches, or any other electronic component. Do not lift the chair by cables or wires.
3. Do not lift the wheelchair with the child in it.

## **Transporting the chair**

1. The best way to transport the chair is in a van with wheelchair ramp or lift, and special clamps or straps. Check with the clamp manufacturer that the clamps are strong enough to hold electric wheelchairs.

2. We recommend that the user does **not** sit in the Smart Wheelchair to travel - use an approved seat and restraint belt. If you wish to transport the user in the Smart Wheelchair, check that the clamps can hold the chair; and that the seat and seatbelts are approved for road transportation.
3. The chair can also be transported by car. With an estate, we recommend use of wheelchair ramps. You may have to remove the seat from the wheelchair.
4. You can also fit the Smart Wheelchair into most hatchbacks, provided the seating is removed first. Take care when lifting it in - use wheelchair ramps or lift the chair with three or more people.
5. Make sure the wheels are engaged with the motor as this acts as a braking mechanism to stop it moving around as you are driving.

## **Electronics and controls**

1. Disconnect the charger before entering the chair.
2. Turn the speed to low before using the chair.
3. The DX Power Module, joystick and Smart Controller must not be used in any way other than in the manner described in this manual.
4. All programmable options on the DX Power Module, joystick and Smart Controller must be correctly adjusted for safe operation prior to use.
5. A warning must be conveyed to the wheelchair operator that the controller could cause the chair to come to a sudden stop. In situations where this may affect the safety of the user, this will require the fitting and wearing of a seat belt.
6. Performance adjustments to the DX Power Module should only be made by professionals of the health care field or persons fully conversant with this process and the drivers capabilities. Incorrect settings could cause injury to the driver or bystanders, or damage to the wheelchair or surrounding property.
7. Do not operate the wheelchair if it behaves erratically, or shows abnormal heating, smoke or arcing. Turn the system off at once and consult Smile Rehab.
8. Do not operate the wheelchair if the battery is nearly flat as a dangerous situation may result due to loss of power in an inopportune place.
9. Ensure the controller is turned off when not in use.
10. No connector pins should be touched, as contamination or damage due to electrostatic discharge may result.
11. Most electronic equipment is influenced by Radio Frequency Interference (RFI). The Smart Wheelchair has been designed and tested to meet current standards for immunity from RFI but caution should be exercised with regard to the use of portable communications equipment. If RFI causes erratic behaviour, shut the wheelchair off immediately. Leave off while transmission is in progress.
12. If the AC power lead on the battery charger becomes damaged, the charger should not be used.
13. Report any malfunctions immediately to Smile Rehab.

# Troubleshooting

## **The chair will not switch on...**

- Check the DX cables are securely connected to the joystick, Smart Controller and Power Module.
- Check the Safety Cut-Out button on the right side of the chassis. If it has popped out, press it back in and try switching on again.
- Try charging the batteries first, then switching on.
- If all else fails, contact Smile Rehab.

## **The green light on the Smart Controller flashes when you switch on...**

- If the light is flashing **once** a second, the Smart Wheelchair is in programming mode - turn programming mode off with the *Program* switch on the ToolBox.
- Flashing **twice** a second indicates that a bumper is stuck on, which may mean the bumpers need adjustment (see bump tools section on bumper adjustment). The chair will still operate with stuck bumpers but you will not be able to use the Bump Tools and they should be turned off on the ToolBox. Both of the above conditions are reported by the Speech Synthesiser if you have it connected.

## **The chair stops and the red light on the Smart Controller comes on...**

- means the Smart Controller has detected a fault and switched itself off. Try switching off and on again. If the fault repeats, contact Smile Rehab.

## **The chair drives in different directions when I press the forward switch...**

You probably have Scanning Control switched on - switch it off.

## **The chair chats away as though it's stuck in a loop and behaves strangely when I switch on...**

It has probably lost it's settings. Switch off, hold down *Back* and *Stop* switches, and power up. Then release the switches. The chair should say 'Resetting Tools and Default values', and behave normally. If the chair keeps losing the settings it may be because the backup battery is flat (if the chair has not been used for a very long time, the battery will go flat) and you should contact Smile Rehab for a replacement.

## The green light on the joystick flashes when you switch on...

- the DX Power Module has detected a fault in the system. Switch the chair off, wait five seconds, and then switch on again.
- The light will flash one or more times, then pause, and then flash again. The number of times it flashes is called the Flash Code; different flash codes indicate different faults. The codes and what they mean are listed below. Faults which may effect safety will cause the chair to stop. Some faults are automatically cleared when the fault is fixed; others are 'latched' and must be cleared by switching off, waiting for two seconds, and then switching on again. If the fault is not safety-critical, the chair may go into 'Limp mode' where it can be driven, but only slowly. If a DX fault is shown, first switch the chair off, wait five seconds, and then switch on again. If it still flashes make a note of the flash code and then contact Smile Rehab.

No. of flashes	Fault	Chair stops?	Fault latched?	Limp Mode?
1	DX Module faulty	Depends on module	Depends on fault	If PM or Joystick
2	DX Accessory fault	Depends on fault	Depends on fault	No
3	Left M1 Motor fault	Yes	Yes	No
4	Right M2 Motor fault	Yes	Yes	No
5	Left (M1) Parkbrake fault	Yes	Yes	No
6	Right (M1) Parkbrake fault	Yes	Yes	No
7	Low battery fault	Yes	No	No
8	Over voltage fault	Yes	No	No
9	CANL fault	Yes	No	Yes
10	CANH fault	Yes	Yes	Yes
11	Stall Time Out	Yes	Yes	No
12	Module mismatch	Yes	Yes	No

When you want to turn the wheelchair off (whether or not the chair is running i.e. in an emergency or at the end of a session), just press the on/off button on the joystick.

## The chair does not move when I press the switch...

There are several reason why this may be happening. Follow the table below to try and find the reason - if you can't, phone Smile Rehab.

OBSERVATION	SOLUTION
Is the wheelchair switched on?	Switch it on.
Are the wheels engaged?	Engage the wheels
Is the Joystick on Mode 1?	If not, set to Mode 1
Is the speed turned right down?	Turn it up
Is Scanning selected	Turn scanning off
Is Programme Mode on?	Turn Programme Mode off
Has the chair just hit a bump?	Back away from the bump and try again.
Has the chair just hit a bump particularly hard?	Check the Safety Cut-Out button has not popped out - press it in.
Has the speed been altered with the programming switch?	Check and if necessary adjust it
Switch on Motion Speech. Does the chair say 'I'm going ....' when the switch is pressed?	If yes, and the chair does not move, there is a fault with the Smart Controller or the DX Power Module. Contact Smile Rehab.
Is the switch light on the front panel coming on when the switch is pressed?	If yes, then the switch is OK. If not, either the switch is faulty or there is a fault in the Smart Controller.
Plug a different switch into the socket	If it works, the switch is duff. If it doesn't work, the Smart Controller may be faulty.
Plug the switch into a different socket	If it works, the first socket may be faulty. If not the switch or the Smart Controller is faulty

## The chair does not follow the line properly...

OBSERVATION	SOLUTION
Is Line Following switched on on the toolbox?	Switch it on.
Is the Line Follower unit plugged into the front of the Smart Controller?	If not, plug it in
Wave some tape under the Line Follower. Do ALL the 'Line Sensor' lights light up on the Smart Controller front panel as the tape is	If yes, the line follower is working OK. If one light does not come on, one of the line sensors may be faulty - contact Smile Rehab. If no
The chair swings out at corners	Use wider, gentler corners.
The chair moves too slowly on the line	Try increasing the Line Following speed with the Programming Switch - but carefully.
The chair does not 'find line' when it goes across it	Approach the line more slowly
The chair does not 'lose line'	Have a straight piece of tape before the line stops
The chair does not detect junctions	Switch Line Junctions on. See Section 10 on laying line junctions.

# Suppliers

If you need help with anything to do with the Smart Wheelchair, contact Smile Rehab in the first instance.

However, the chair is designed so that you can try out different switches, controls, training ideas and activities **without** having to always call in an engineer or technician, or occupational or physiotherapist. To help you with this, we have listed some suppliers of switches and controls below. It is worth obtaining their catalogues so you have a good idea of what is available.

**CALL Centre**, University of Edinburgh, Paterson's Land, Holyrood Road, Edinburgh, EH8 8AQ. Tel. 0131 651 6236. <http://callcentre.education.ed.ac.uk>. *Designers of the Smart Wheelchair.*

**Controls Dynamic**, Lisle Avenue, Kidderminster, Worcs.. Tel. 01562 820 055  
[www.DynamicMobility.co.nz](http://www.DynamicMobility.co.nz). *Manufacturers of wheelchair controllers and joysticks.*

**Dudley Controls Ltd.**, 10 Peverel Drive, Milton Keynes, Bucks MK1 1NL. Tel. 01908 640777. *Manufacturers of wheelchair controllers, joysticks and switches.*

**Cambridge Adaptive Communication**, The Mount, Toft, Cambridge CB3 7RL. Tel. 01223 264 244. [www.camad.demon.co.uk](http://www.camad.demon.co.uk). *Suppliers of switches and switch mounts, communication aids, access devices and software.*

**CPC**, Component House, Faraday Drive, Fulwood, Preston, Lancs. PR2 9PP. Tel. 01772 654455. <http://www.cpc.co.uk>. *Electronic components - good for cables, adapters, velcro and general components.*

**Inclusive Technology**, Saddleworth Business Centre, Huddersfield Road, Oldham OL3 5DF, Tel. 01457 819790. <http://www.inclusive.co.uk> *Switches and switch mounts, plus Mac and PC SEN software and hardware.*

**QED 2000**, 1 Prince Alfred Street, Gosport, Hampshire, PO12 1QH. Tel: 0870-78-78-850. *Suppliers of a very wide range of switches, switch mounts, interfaces and communication devices, including TASH switches and Mobilia switch mounts.*

**SEMERC**, Granada Learning, Granada Television, Quay Street, Manchester M60 9EA. Tel. 0161 827 2927. <http://www.semmerc.com>. *Switches, switch mounts, and Acorn and PC SEN software and hardware.*

**Smile Rehab Ltd.** 3 Bone Lane, Newbury RG14 5SH. Tel. 01635 42305  
<http://www.smilerehab.com/> *Manufacturers of the Bobcat and Smart Wheelchairs.*

**Techcess**, Unit 12, Willow Park Industrial Estate, Upton Lane, Stoke Golding, Nuneaton, Warwickshire CV13 6EU. Tel. 01455 213708. *Suppliers of a wide range of switches, and other devices including TASH switches and Daessy mounts..*

